

ULTRACAPACITORS FOR WIND POWER APPLICATIONS

Pitch Control

Ultracapacitors have been established as the energy storage medium of choice in wind systems. Enercon first commercially integrated them in 2006 for the purpose of pitch control and emergency power for the pitch control systems. Ultracapacitors proved superior to the incumbent battery systems by performing beyond the limitations of the batteries. In particular, ultracapacitors maintain a high level of performance in cold temperatures and have a very long cycle/calendar life while generally requiring no maintenance. A typical schematic is provided showing the location of the energy storage component (batteries or ultracapacitors) within a pitch control system. The

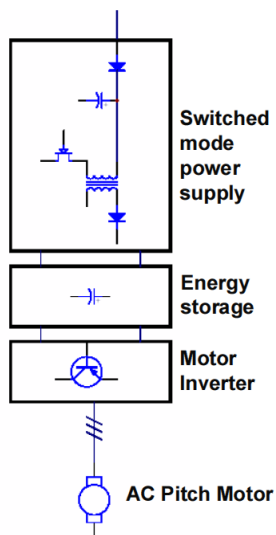

switched mode power supply serves as the charging circuit for the energy storage component. The energy storage subsequently powers the motor controllers aka inverter or VFD, which controls the pitch motor. One of these systems is required for each blade to make a complete pitch control system. For redundancy the systems remain isolated.

Pitch control systems dynamically adjust blade position relative to wind speed in order to maximize efficiency for power generation. Additionally, this pitch control is a necessary safety feature for when wind speeds are too high or grid connection to the wind mill is lost. In either case the pitch control adjusts the blade position to neutral; acting as a break for the turbine system. A reliable system for these emergency type situations is paramount. Typically at least 2 functioning systems are required to bring a windmill to rest.

While the power supply can be located as part of the rotating assembly or stationary inside the hub, the energy storage for reliability is often located in the rotating assembly. These requirements limit your choices of energy storage and the nature of ultracapacitors as light weight and nearly solid state devices make them a top choice. Heavier batteries require much more significant structure to support them in rotation as well as insulation to stave off the effects of cold. In cold weather climates the higher power capability of ultracapacitors compared to batteries translates to faster response time for similarly designed systems. Other requirements include venting to remove hydrogen gas build up from cycling the batteries as well as protection from moisture and management systems to maximize their life. The requirements of ultracapacitors are simple by comparison. They require some protection from moisture, some very inexpensive balancing circuitry and a designed charge (float) voltage that will maximize their life.

The transition from battery to ultracapacitor based designs has contributed to improved economics for wind farm operation. Ultracapacitors are capable of long operational life exceeding 10 years. Additionally, the ultracapacitors require no maintenance and the state of health is easily ascertained. Batteries on the other hand have life times typically $\frac{1}{2}$ to $\frac{1}{3}$ that of ultracapacitors depending on the

environmental conditions. End of life is less predictable and frequent maintenance is required. These economics are even more amplified when considering offshore wind installations.

The extreme conditions presented by offshore windmills have proven the value/ROI of ultracapacitors as the energy storage systems of choice. In the North Atlantic where maintenance is difficult and costly and temperatures reach extreme lows for long periods of time; ultracapacitors provide years of unmaintained security and reliability. Providing energy for the largest pitch control systems on the planet (6MW mills are typically only located off shore because of their extreme size [200m diameter rotors]).

Power Conditioning

Energy storage can also be beneficial as an interface between the wind farm and the electrical grid. As the contribution of wind power to the electrical grid increases, the grid becomes more susceptible to voltage fluctuations associated with rapid wind speed changes. Wind speed changes of up to 10% in a couple of seconds are not uncommon. An electronic shock absorber (ESA) can minimize the effects of these changes on the power quality coming from the wind mill or wind farm. An example schematic is provided in the following line diagram.

S&C Electric developed the first ESA which acts as a grid interface between the wind farm bus and the utility grid. Ultracapacitors are contained within an outbuilding or trailer near the wind farm, providing the energy storage component for the voltage smoothing interface. Depending on the size of the farm, this concept can also be applied to the windmill itself. Rather than a single interface between the wind farm bus and the utility grid, each individual windmill can provide voltage buffering or smoothing to the grid.

ESA Single Line Diagram

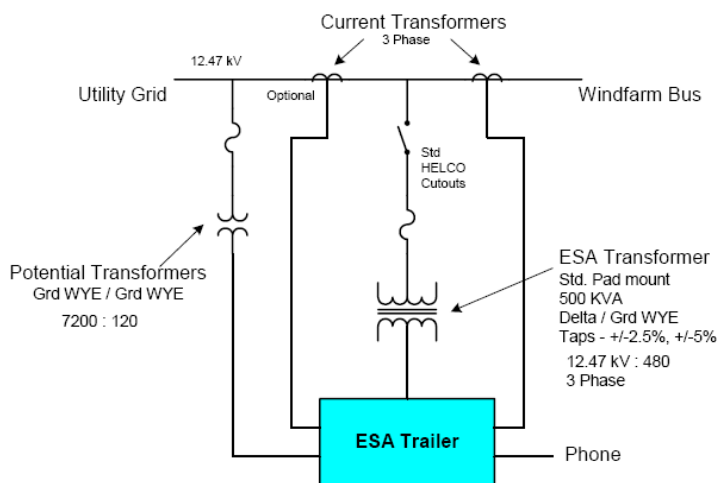

As in the pitch control application, ultracapacitors can provide superior economics in the ESA application because of their ability to perform over a wider range of temperatures than batteries, their significantly higher efficiency relative to batteries for short term energy storage, and their vastly longer cycle life. Ultracapacitors have extremely low ESR, allowing them to be efficiently charged and discharged very rapidly. They also do not need to be kept at a minimum voltage in order to maximize their life. Ultracapacitors are perfectly suited to be kept at any voltage at or below their rated voltage



for extended periods of time, allowing them to be flexible to the needs presented by the environment on a wind farm. Their efficiency and wide temperature range minimizes the need for auxiliary temperature controls and their ability to function over a wide voltage range reduces or eliminates management systems that add cost, complexity and inefficiency to the ESA systems.

Conclusion

Ultracapacitors used as energy storage in wind applications generate far better ROI than other energy storage mediums in all phases of a windmills life.

Simple design

- Predictable operation
- Very little support architecture
 - Light weight
 - Wider temperature range than batteries
 - Typically no Insulation or cooling required
 - No hydrogen venting required
- Elimination of management schemes

Easy use

- No maintenance
- Reliable operation
- Long life (10 years or more)

Easy disposal

- Product is >95% recyclable
- Recycle by shipping to recycler
 - ~\$0.35/lb

For additional information on Ioxus products or applications, please contact sales by e-mailing: info@ioxus.com or by calling 1-877-751-4222.